

Hotels

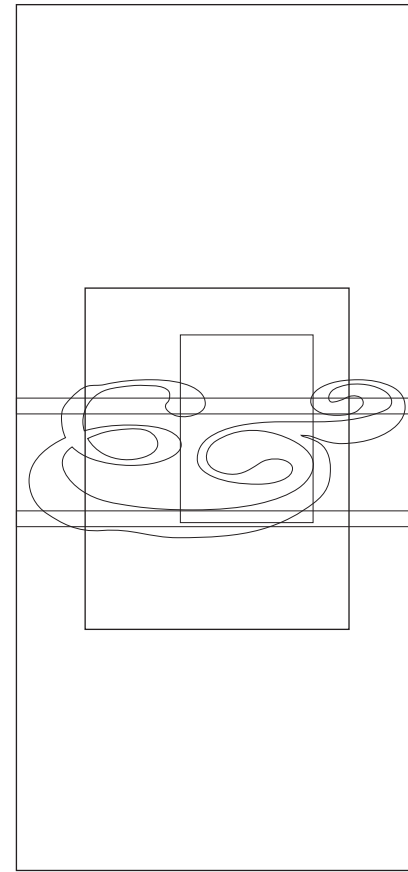

Re

*Every little town on the island had a hotel.*

*To appease the appetites of guests arriving from every possible direction of the continent, a merge of the specialities representing the different regions of the tectonic plate was assembled.*

*“[...] by creating security through the known and at the same time satisfying curiosity.*

*It was to be what was considered good pop.“*

*The continental breakfast,*

*continental roughly translated contiguous lands, seemed to unite culinary representations from all points of the compass. Much like supergroups in music or the all-star team in basketball. Usually served between 07:00 and 10:00 a continental breakfast includes: orange juice, black tea/coffee, mostly filtered coffee, pastries: croissant, dry toast and dark bread. Northern fruit in the form of jams and spreads. for the savoury: sliced cheese and ham. Eggs and cereals optional.*

*,Ghosttown‘ - Daniel Fonatti*